

SPARE PARTS & ACCESSORIES

Spare Parts

Description	Part Number
Drive tray, Type-III bezel and Type-II LED lightpipe	IFT-9273CDTray
Power supply, 530W capacity	IFT-9273ECPSU
Cooling fan	IFT-9273ECFanMod
Controller module	IFT-83AE21GE164
Controller module with 512MB DDR	IFT-83AE21GE1645
Left-side forearm handle with LCD panel for 3U RAID subsystems	IFT-9273CHandLLCD
Right-side forearm handle for 3U subsystems; for the left or right side of JBOD subsystems	IFT-9270CHandR

Accessories

Description	Part Number
Shielded Twisted-pair Ethernet cable, 3 meters	IFT-9273CSTPCab
Dummy Drive tray, Type-III bezel	IFT-9273CDTrayDmy
Li-Ion battery cell pack (4 cells), w/ EEPROM for event notification when life expectancy is exceeded	IFT-9273CBTE
UPS serial cable	IFT-9270CUPSCab
RS-232C serial cable, audio-jack to DB (* One included in kit)	IFT-9270ASCab
Null modem, DB9 female to DB9 male, wires swapped (* One included in kit)	IFT-9011
512MB DDR RAM DIMM module for ASIC400 platform	IFT-DDRESCM5
1GB DDR RAM DIMM module for ASIC400 platform	IFT-DDRESCMA
2GB DDR RAM DIMM module for ASIC400 platform	IFT-DDRESCMB
Slide rail assembly, for ES 3U-16bay subsystem, 28" to 36" rack depth	IFT-9273CSlider32
Slide rail assembly, for ES 3U-16bay subsystem, 32" to 36" rack depth	IFT-9273CSlider36



www.infotrend.com



Asia Pacific
Infotrend Technology, Inc.
 8F, No. 102 Chung-Shan Rd., Sec. 3
 Chung-Ho City, Taipei Hsien, Taiwan
 Tel: +886-2-2226-0126
 Fax: +886-2-2226-0020
 sales.ap@infotrend.com
 support.ap@infotrend.com
 http://esupport.infotrend.com.tw
 http://www.infotrend.com.tw

Americas
Infotrend Corporation
 3150 Coronado Dr., Unit C
 Santa Clara, CA 95054, USA
 Tel: +1-408-988-5088
 Fax: +1-408-988-6288
 sales.us@infotrend.com
 http://esupport.infotrend.com
 http://www.infotrend.com

Europe
Infotrend Europe, Ltd.
 5 Elmwood, Crockford Lane
 Chicheam Business Park
 Basingstoke, Hampshire
 RG24 8WG, UK
 Tel: +44-(0)1256-70-77-00
 Fax: +44-(0)1256-70-78-89
 sales.eu@infotrend.com
 support.eu@infotrend.com
 http://esupport.infotrend-europe.com
 http://www.infotrend.com

China
Infotrend Technology, Ltd.
 Room 1210, West Wing, Tower One,
 Junefield Plaza, No. 6 Xuanwumen Street,
 Xuanwu District, Beijing, China. 100052
 Tel: +86-10-63106168
 Fax: +86-10-63106188
 sales.cn@infotrend.com
 support.cn@infotrend.com
 http://esupport.infotrend.com.cn
 http://www.infotrend.com.cn

Japan
Infotrend Japan, Inc.
 6F Okayasu Bldg., 1-7-14 Shibaura,
 Minato-ku, Tokyo, 105-0023 Japan
 TEL: +81-3-5730-6551
 FAX: +81-3-5730-6552
 sales.jp@infotrend.com
 support.jp@infotrend.com
 http://esupport.infotrend.com.tw
 http://www.infotrend.co.jp

Copyright © 2006 by Infotrend Technology, Inc. All rights reserved.
 • Any information provided herein is without warranties of any kind and is subject to change by Infotrend without prior notice.
 • Infotrend offers a 3-year limited warranty on subsystems and a 1-year warranty on battery backup units.

• Infotrend and the Infotrend logo are registered trademarks of Infotrend Technology, Inc.
 • EonStor and RAIDWatch are registered trademarks of Infotrend Technology, Inc.
 • All other names, brands, products, or services are trademarks or registered trademarks of their respective owners.

EonStor® A16E-G2130-4

3U Profile, Single-controller
 16-drive, iSCSI to SATA RAID Subsystem



The A16E-G2130-4 subsystem is a power-boost version of Infotrend's iSCSI series with hardware RAID6 (by the latest ASIC400), RoHS-compliant hardware, and 1GB more internal bandwidth than previous EonStor. With abundant bandwidth and computing power, the iSCSI RAID comes with four (4) GbE host ports and is able to satisfy the increasing demands for storage space with block-level performance and the unparalleled RAID5 and RAID6 protection.

Leading the trend of intelligent RAID storage, the A16E is a seamless integration of Infotrend's innovative RAID technologies with iSCSI protocols that encapsulate SCSI data blocks and carry them over sophisticated Ethernet infrastructures. With the EonPath™ multi-path software and intelligent load-balancing algorithms, the subsystem readily joins into environments requiring a reliable storage pool. The subsystem is designed for a wide variety of applications, be it a quick addition to departmental needs, data warehousing, databases, or as a secondary storage besides a large storage network.





OVERVIEW

The A16E storage array is ideal for building a shared storage pool for disk-to-disk volume distribution, backup, storage consolidation, and replication of data among networked servers. The A16E array operates with the advantages of iSCSI protocols in terms of its block-based performance, low training and maintenance costs, and especially without the complexity of other storage network technologies such as the Fibre Channel.

HIGHLIGHTS

- 4 x 1GbE host ports
- Compliant with IETF iSCSI
- Network security over one-way/mutual CHAP, IQN, and IP access control
- Supports up to 32 host access
- Jumbo frame support
- Intelligent load-balancing; internally & between host links by the EonPath™ multi-path software
- Comprehensive browser-based RAIDWatch GUI.
- Sixteen (16) SATA-II, 3Gb drive bays; backward compatible with SATA-I
- SATA S.M.A.R.T., and NCQ support
- Comprehensive management tools and event notification methods
- Life expectancy aware Li-Ion battery backup

Reliability

Infortrend's RAID subsystems are renowned for a complete list of RAID configuration choices in terms of RAID levels, performance parameters, and proactive fault management. A configured RAID array is not only protected by drive redundancy, but also the rich variety of protection features ranging from media error recovery to the management of faulty components.

EonPath multipathing drivers are now available for application servers running Windows, Solaris, or Linux operating systems. EonPath provides multipath IO function by recognizing and managing the fault-tolerant data paths to an individual RAID volume. Greater reliability is achieved through the path failover mechanism in the event of cabling component failure. The EonPath also comes with load-balancing algorithms which help accelerate the throughput across host-storage data links.

Availability

Throughout the decade, our sophisticated firmware core runs a million RAID arrays around the globe, in numerous applications and harsh environments.

To ensure a high level of system availability, critical components such as power supplies and cooling fans are configured in redundant pairs. Modules are integrated with the main signal path PCB via board-to-board or interface-specific connectors to eliminate points of failure. Assisted by GUI management software, an administrator is constantly aware of all component statuses through a local or remote console.

Manageability

All critical components are housed in their own removable canisters, including hard disk drives, power supplies, battery module, and cooling fans. In the event of component failure, each can be replaced within seconds. A variety of configuration and monitoring methods are available, either locally via the LCD keypad, text-mode terminal emulation, or remotely through the browser-based or Java-based RAIDWatch manager. All fault conditions, including module failure, abnormal voltage and temperature readings, are instantly reported.

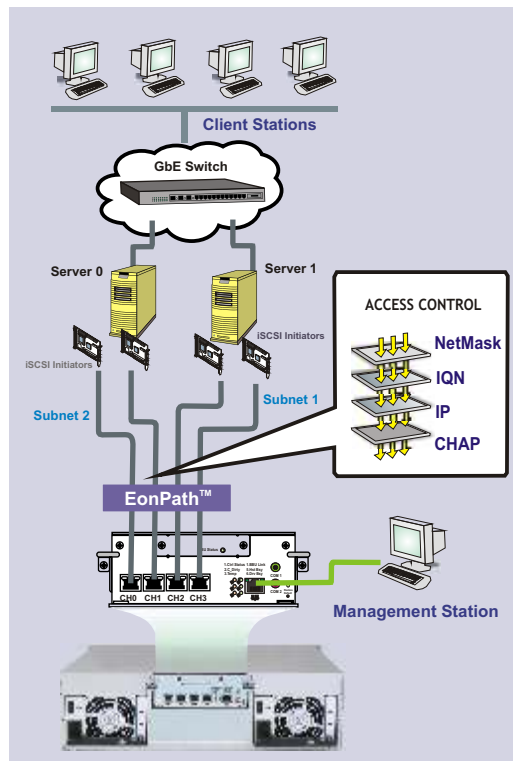

INFOTREND SMART TECHNOLOGIES

Derived from a decade of experience in RAID storage design, our firmware features extremely compact protocol and rich varieties of algorithms to deal with the stringent demands of today's storage applications. The technologies are smart enough to handle various I/O characteristics, drive media defects, and system fault conditions.



MAJOR MARKETS AND USES

Infortrend products are used in server-attached and networked data storage environments in major industries such as medical imaging, multi-media on demand (MOD), and digital media including video-on-demand, stream editing and many others.

IO Smart

The IO Smart technologies consist of specific configuration options that control various I/O characteristics in order to meet the rapidly increasing requirements of today's applications. The functions include adaptable stripe size, adaptive write policy and guaranteed latency I/O which improve sequential write performance and ensure fast and efficient data flow. The AV optimization options provide means to adapt to applications with multi-threaded and various I/O queue depths.

DrvSmart

DrvSmart is comprised of fault-preventive algorithms that ensure data integrity when conditions related to hard drive imperfections occur. DrvSmart mechanisms correct minor defects, increase reaction time, allow more time to prepare a rebuild, and help minimize performance impact. DrvSmart features include Media Scan & Task Scheduler, hot-spare, drive roaming, SMART and manual cloning options, and transparent resetting of non-responsive hard drives.

SysSmart

SysSmart combines enclosure monitoring and firmware management capabilities to minimize the chance of downtime caused by hardware failures. Other SysSmart functions include event-triggered as well as other monitoring utilities and approaches combined with the powerful RAIDWatch manager. Component status, voltage and temperature readings, and system events are instantly revealed through the manager's graphical interface.



SPECIFICATIONS

Subsystem Characteristics

- PowerPC RISC CPU, 1MB L2
- ASIC400 RAID engine
- Default DDR cache memory 512MB
- GbE host port 4
- Fast Ethernet management port 1
- COM ports 2
- 10/100 Ethernet port 1
- BBU Optional
- PSU 2
- Cooling module 2

iSCSI

- CHAP (one-way & mutual)
- Jumbo Frames
- IQN & IP access control

Drive Interface

- Number of disk trays 16
- S.M.A.R.T.
- NCQ support

Host Interface

- Host ports 4
- Data single channel bandwidth 1Gb/s
- Tag command queuing 256
- Multiple target IDs

RAID Configurations

- RAID levels 0, 1(0+1), 3, 5, 6, 10, 30, 50, 60, JBOD
- Max. 32 logical drives (varied by memory size)

- Max. 1024 LUNs (varied by memory size)
- Multiple array configurations
- Automatic background rebuild
- Infortrend Smart, proactive fault management technologies
- RAID level migration

High Availability

- Subsystem self-diagnostics
- Multiple Local, Global, and Enclosure-specific Hot-spares
- Parity regeneration and media scan scheduler
- Automatic, background, and concurrent rebuild

Management

- Browser-based and Java-based RAIDWatch GUI software
- Terminal via RS-232C
- Telnet over Ethernet
- Event notification methods:
 - Email
 - Fax
 - LAN broadcast
 - SNMP traps
 - Cell phone message SMS
 - Instant messages MSN

OS Support

- Microsoft Windows XP
- Microsoft Windows 2000 Server
- Microsoft Windows 2003 Server
- Sun Solaris ver. 9/10
- Red Hat Linux ver. 9/10, Enterprise ver. 3, 64 bit
- SuSE: Linux ver. 8/9, 64 bit

Requirements

- AC Input: 100VAC ~ 240VAC 530W with PFC (auto-switching)
- DC Output: 12V-32A; 5V-32A; 3.3V-30A
- Relative Humidity: 5% to 95% non-condensing
- Operating Temperature: 0°C to 40°C (without BBU) 0°C to 35°C (with BBU)

Dimensions

- 3U, 19-inch rackmount chassis
- Without handles: 445(W) x 130(H) x 488.2(D) mm (17.5 x 1.7 x 20.1 inches)
- With handles: 482.6(W) x 131(H) x 504.3(D) mm (18.8 x 1.7 x 20.1 inches)